

Model **KMDE-V** STATIONARY DEMAGNETIZER FOR RING WORKPIECE

Workpieces need not be turned over; work efficiency enhanced!



KMDE-V2525

An example of demagnetization of special ring-shaped workpiece



Control unit required additionally

[Application]

Suitable for demagnetization of ring-shaped workpieces.

[Features]

- One step of operation completes the demagnetizing work. Workpieces need not be turned over, thus eliminating a fear of damaging the workpieces.
 - The protective plates provided on the demagnetizing V-faces prevent damage to workpieces. Workpieces of various shapes can be demagnetized properly by changing the protective plates.
 - The demagnetizer itself and the control unit are installed separately. Thus, they can be installed in an easy-to-operate place.
- ※ A drip-proof type is available optionally. Please contact us.

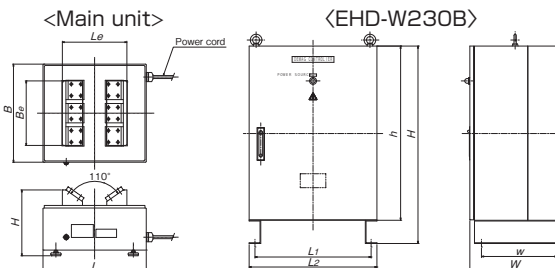

Main unit

[mm (in.)]

Model	Dimensions			Demagnetizing Area Be×Le	Applicable Ring Size Diameter Width	Electrical Rating	Working Rate	Mass	Applicable Control Unit
	B	L	H						
KMDE-V2525	380 (14.9)	400 (15.7)	250 (9.84)	250 (9.84) × 250 (9.84)	φ 150 – φ 350 (8.66)	180 VDC /9A	10% ED	90kg/ 198 lb	EHD- W210B
KMDE-V4040	640 (25.1)	640 (25.1)	390 (15.3)	400 (15.7) × 400 (15.7)	φ 250 – φ 600 (13.7)	180 VDC /26A		450kg/ 992 lb	EHD- W230B

※ KMDE-V2525 comes with a 3 m power cord and KMDE-V4040 with a 5 m cord.

Applicable control unit

[mm (in.)]

Model	Dimensions						Power	Output	Mass
	L ₁	L ₂	W	w	H	h			
EHD-W210B	190 (7.48)	220 (8.66)	175 (6.88)	—	290 (11.4)	250 (9.84)	Single-phase 200 VAC	180 VDC /10A	6kg/ 13.2 lb
EHD-W230B	500 (19.6)	550 (21.6)	400 (15.7)	325 (12.7)	850 (33.4)	750 (29.5)	3-phase 200 VAC	180 VDC /30A	48kg/ 105 lb

※ EHD-W230B comes with a dedicated controller.
※ For the dimensions of EHD-W210B, see "EHD dimensions" on page 121.

Model **KMDV** V-TYPE DEMAGNETIZER



An example of special fabrication of KMDV

Demagnetization of ring-shaped workpieces and hardened materials!

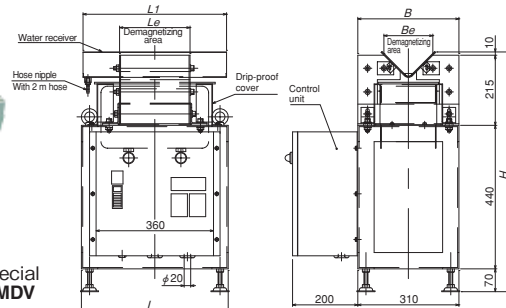

[Application]

Used to remove residual magnetism in magnetized ring-shaped workpieces.

[Features]

- The V-shaped core design ensures effective demagnetization of ring-shaped workpieces.
- The strong magnetic field produced enables it to demagnetize hardened materials that are difficult to demagnetize with conventional demagnetizers.
- A water receiver provided in the demagnetizing area enables it to demagnetize wet workpieces also.

[mm (in.)]

Model	Power Source	Source Capacity	Working Rate	Demagnetizing Area		Dimensions				Mass
				Be×Le		L	L ₁	B	H	
KMDV-15	Single-phase 200 VAC, 50/60 Hz	6kVA (30A)	30% ED, 30 minutes max.	150 (5.90) × 216 (8.50)		450 (17.7)	440 (17.3)	310 (12.2)	735 (28.9)	170kg/374 lb

Demagnetization is turned on with a foot switch and turned off automatically by the timer. (Timer setting 60 seconds max.)

Model **KMDU** U-TYPE DEMAGNETIZER

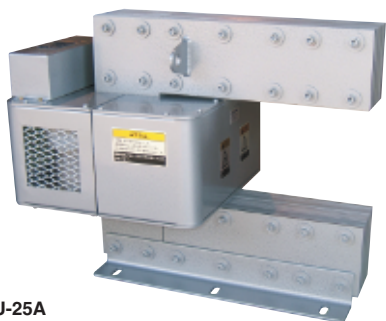

KMDU-25A

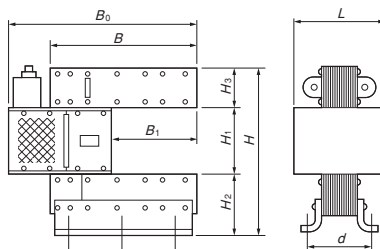

[Application]

Suitable for demagnetizing bobs and die sets. Since its magnetic flux alternates vertically, this model is also recommended where long and irregularly shaped workpieces need to be demagnetized uniformly. Further, this model can easily be incorporated in a conveyance system.

[Features]

- Easy to incorporate in a conveyance system and easy to remove and relocate.

[mm (in.)]

Model	Power Source	Source Capacity (Current)	Working Rate	Dimensions											Mass
				B ₀	B	B ₁	H	H ₁	H ₂	H ₃	L	d			
KMDU-25A	Single-phase 200 VAC, 50/60 Hz	14kVA (70A)	30% ED,	630 (24.8)	500 (19.6)	250 (9.84)	480 (18.9)	200 (7.87)	150 (5.90)	130 (5.11)	350 (13.7)				180kg/ 397 lb
KMDU-50A	Single-phase 220 VAC, 60 Hz	30kVA (150A)	30 minutes max.	940 (37.0)	770 (30.3)	500 (19.6)	715 (28.2)	300 (11.8)	215 (8.46)	200 (7.87)	420 (16.5)		270 (10.6)		600kg/1323 lb

※ A different-voltage type (special type) is also available.

MAGNETIC TOOLS & EQUIPMENT
FOR WELDING OPERATION
LIFTING
MAGNET
MAGBONE
MAGNETIC EQUIPMENT
FOR CONVEYANCE
CHIP & SLUDGE
CONVEYANCE EQUIPMENT
ENVIRONMENTAL
EQUIPMENT
MAGNETIZER AND
DEMAGNETIZER
MAGNETIC EQUIPMENT
FOR CONVEYANCE
MAGNETIC
SEPARATORS
POWERFUL MAGNETIC
SEPARATORS
MEASURING
TOOLS
MEASURING
INSTRUMENTS
MAGNETIC
MATERIALS