

Model KCD-M MINI TYPE MAGBORE* (KCD-MN1 model in the USA)

Portable, compact, magnetic drill stand.

[Features]

- Mini size weighing only 7 kg. Can be handled easily by female workers.
- Attracting firmly even to thin plates of 5mm thickness, it assures high precision drilling work.

[Parts for sale !]

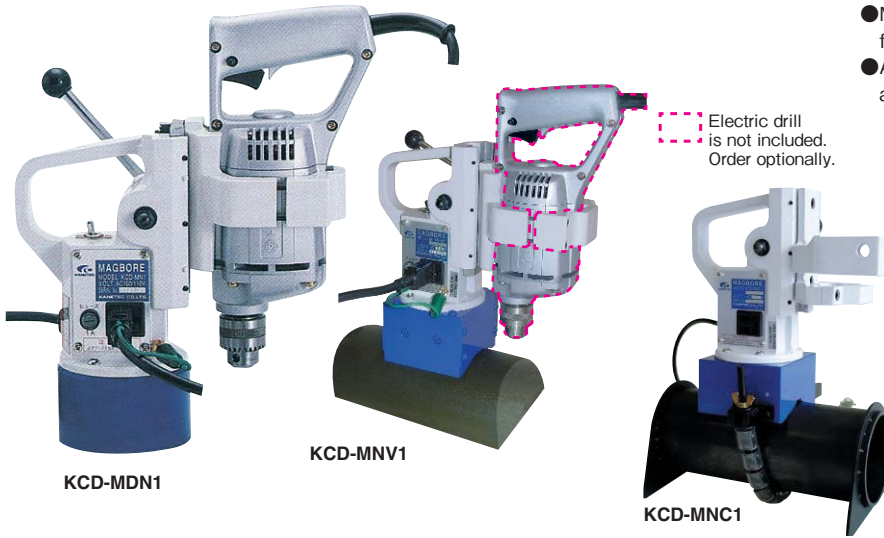
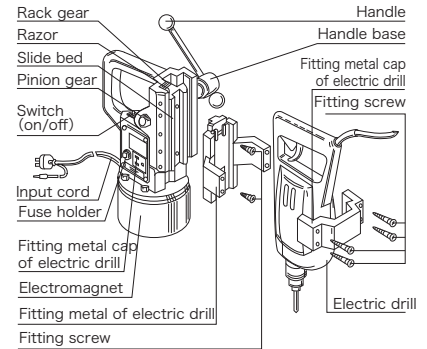

[mm (in)]

Model	Applicable Drill	Drill Dia	Power Source	Allowable Drilling Force	Holding Power	Dimensions		Max. Stroke	Mass	Remarks
						Magnet	Height			
KCD-MN1	6.5 (0.25)	1.5 (0.05) — 6.5 (0.25)	Single-phase 100 / 110 VAC	1kN (100kgf)	3.5kN (350kgf)	φ 105 (4.13) × 60 (2.36)	240 (9.44)	100 (3.93)	5.5kg / 12 lb	Without electric drill
KCD-MDN1									7kg / 15 lb	With electric drill

※ Cord length 2m. ※ The holding power applies to black plate of SS400 and thickness 10 mm.
 Two models of KCD-M Series for round steels and pipes of φ80 to φ200 available.
 ■ KCD-MNV1...Magnetic holding Round steel : 0.9N—1.1kN (90—110kgf) ■ KCD-MNC1...Chain clamp type and thus can be used for nonmagnetic materials also.
 power for Steel plate : 1.2kN (120kgf) (Not electromagnetic type, and thus no magnetism)

Model KCD-N MINI TYPE MAGBORE*

Portable magnetic force holding drilling machine with round electromagnet

[Parts for sale !]

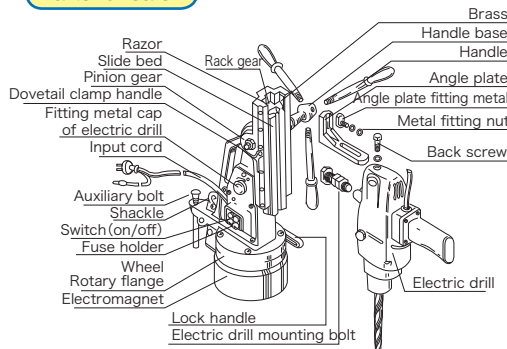

Circular magnet is turnable up to 320°. You can even drill thin steel sheet by placing backing material beneath the sheet

[Features]

- A portable version of the bench drilling machine. Capable of drilling 20-mm holes in workpieces 20 mm or thicker.

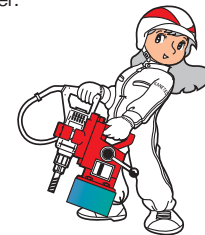

[mm (in)]

Model	Applicable Drill	Drill Dia	Power Source		Allowable Drilling Force	Holding Power	Dimensions		Max. Stroke	Turning Angle	Fine Length	Mass
			Voltage	Power			Magnet	Height				
KCD-1NA	10 (0.39) — 13 (0.51)	1.5 (0.05) — 13 (0.51)	Single-phase 100 VAC	34W	4kN (400kgf)	8kN (800kgf)	φ 142 (5.59) × 70 (2.75)	355 (13.9)	140 (5.51)	320°	30 (1.18)	15.0kg / 33 lb

※ Cord length 5m. ※ The holding power applies to black plate of SS400 and thickness 10 mm.

List of applicable electric drills by models of Magbore

(Makers in alphabetical order)

Magbore	Hitachi	Makita	Ryobi Towa	Toshiba
KCD-MN1 KCD-MNV1 KCD-MNC1	6.5LUh-7 6.5LUh-DH4			
KCD-1NA	10 NU-DH4 13 BU-PN3 13 BUL-SH3	10 6010N		DRD-10C DRD-13C

※ There are various mounting metals. When purchasing a Magbore, please provide us with information about the manufacturer of the electric drill to use and its model No.
 ※ Mounting metals for drills other than Hitachi drills are supplied at extra cost.

