

**Model KER ELECTROMAGNETIC PULLEY**

These pulleys have been widely used in wastes processing systems, and used to remove iron from bulk materials in chemical, steel making, coal, food and mining industries. The electromagnet pulley is equipped with a rectifier having an ammeter. The power source is single-phase 200 VAC and the output is 180 VDC.

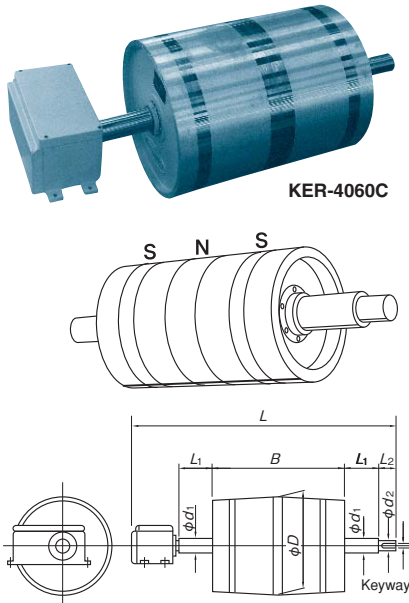

Model	Belt Width	Dimensions								Power Consumption	Mass	Applicable Rectifier
		φ D	B	L	φ d <sub>1</sub>	φ d <sub>2</sub>	L <sub>1</sub>	L <sub>2</sub>	Keyway			
KER- 3030C	300(11.8)	300 (11.8)	350(13.7)	880(34.6)	50(1.96)	45(1.77)	130(5.11)	60(2.36)	14(0.55) × 5.5(0.21)	300W	140kg/ 308 lb	KR-A203
KER- 3035C	350(13.7)		400(15.7)	930(36.6)						490W	155kg/ 341 lb	
KER- 3040C	400(15.7)		450(17.7)	980(38.5)						400W	175kg/ 385 lb	
KER- 3045C	450(17.7)	400 (15.7)	500(19.6)	1030(40.5)	60(2.36)	55(2.16)	140(5.51)	70(2.75)	16(0.62) × 6(0.23)	450W	195kg/ 429 lb	KR-A208
KER- 3050C	500(19.6)		550(21.6)	1110(43.7)						490W	210kg/ 463 lb	
KER- 4040C	400(15.7)		450(17.7)	1030(40.5)						55(2.16)	50(1.96)	
KER- 4045C	450(17.7)	500 (19.6)	500(19.6)	1080(42.5)	65(2.55)	60(2.36)	160(6.29)	80(3.15)	18(0.70) × 7(0.27)	620W	430kg/ 948 lb	R-A215
KER- 4050C	500(19.6)		550(21.6)	1140(44.8)						1000W	700kg/ 1543 lb	
KER- 4060C	600(23.6)		650(25.5)	1240(48.8)						800W	560kg/ 1235 lb	
KER- 4075C	750(29.5)	600 (23.6)	820(32.2)	1430(56.3)	80(3.15)	75(2.95)	170(6.69)	100(3.93)	20(0.78) × 7.5(0.29)	1000W	700kg/ 1543 lb	KR-A230
KER- 5050C	500(19.6)		550(21.6)	1169(46.0)						950W	730kg/ 1609 lb	
KER- 5060C	600(23.6)		650(25.5)	1279(50.3)						1000W	900kg/ 1984 lb	
KER- 5075C	750(29.5)	900 (35.4)	820(32.2)	1449(57.0)	110(4.33)	95(3.74)	230(9.05)	180(7.08)	25(0.98) × 9(0.35)	1300W	1130kg/ 2491 lb	LMT-A240
KER- 5090C	900(35.4)		1000(39.3)	1649(64.9)						1500W	1300kg/ 2866 lb	
KER- 6060C	600(23.6)		650(25.5)	1299(51.1)						1200W	1320kg/ 2910 lb	
KER- 6075C	750(29.5)	750 (29.5)	820(32.2)	1479(58.2)	135(5.31)	110(4.33)	230(9.05)	200(7.87)	28(1.10) × 10(0.39)	1500W	1580kg/ 3483 lb	LMT-A250
KER- 6090C	900(35.4)		1000(39.3)	1679(66.1)						1800W	1900kg/ 4189 lb	
KER- 7590C	900(35.4)		1100(43.3)	2020(79.5)						2800W	1800kg/ 3968 lb	
KER- 75100C	1000(39.3)	900 (35.4)	1100(43.3)	2050(80.7)	140(5.51)	120(4.72)	250(9.84)	300(11.8)	32(1.26) × 11(0.43)	3400W	2200kg/ 4850 lb	KR-A230
KER- 75120C	1200(47.2)		1300(51.1)	2170(85.4)						3800W	2600kg/ 5732 lb	
KER- 75150C	1500(59.0)		1600(62.9)	2570(101.2)						4200W	3100kg/ 6834 lb	
KER- 90100C	1000(39.3)	1000 (39.3)	1100(43.3)	2050(80.7)	140(5.51)	120(4.72)	250(9.84)	300(11.8)	360(14.1)	4300W	3000kg/ 6614 lb	KR-A230
KER- 90120C	1200(47.2)		1300(51.1)	2280(89.7)						4700W	3500kg/ 7716 lb	
KER- 90150C	1500(59.0)		1600(62.9)	2670(105.1)						5200W	4400kg/ 9700 lb	
KER-100120C	1200(47.2)	1000 (39.3)	1300(51.1)	2490(98.0)	140(5.51)	120(4.72)	250(9.84)	300(11.8)	360(14.1)	5500W	4200kg/ 9259 lb	LMT-A240
KER-100150C	1500(59.0)		1600(62.9)	2900(114.2)						6500W	5000kg/ 11023 lb	
KER-120120C	1200(47.2)		1300(51.1)	2490(98.0)						6500W	5400kg/ 11905 lb	
KER-120150C	1500(59.0)	1600(62.9)	2900(114.2)	7600W	6500kg/ 14330 lb							

Note: The slip ring SRB-100 is used for 3030C — 4060C and SR-20 for 4075C and over.

**Model KPR PERMANENT MAGNETIC PULLEY**

**Environmentally Friendly** As for separation in wood material for biomass power generator!



Model	Belt Width	Dimensions								Max. Flux Density	Mass
		φ D	B	L	φ d <sub>1</sub>	φ d <sub>2</sub>	L <sub>1</sub>	L <sub>2</sub>	Keyway		
KPR- 2230	300(11.8)	214 (8.42)	350(13.7)	660(25.9)	40(1.57)	35(1.37)	130(5.11)	50(1.96)	10(0.39) × 5(0.19)	80mT (800G) 以上	45kg/ 99 lb
KPR- 2235	350(13.7)		400(15.7)	710(27.9)							52kg/ 114 lb
KPR- 2240	400(15.7)		450(17.7)	760(29.9)							68kg/ 149 lb
KPR- 2735	350(13.7)	265 (10.4)	400(15.7)	710(27.9)	45(1.77)	40(1.5)	140(5.51)	50(1.96)	12(0.47) × 5(0.19)	80mT (800G) 以上	77kg/ 169 lb
KPR- 2740	400(15.7)		450(17.7)	760(29.9)							86kg/ 189 lb
KPR- 2745	450(17.7)		500(19.6)	810(31.8)							100kg/ 220 lb
KPR- 3240	400(15.7)	315 (12.4)	450(17.7)	780(30.7)	50(1.96)	45(1.77)	135(5.31)	60(2.36)	14(0.55) × 5.5(0.21)	80mT (800G) 以上	110kg/ 242 lb
KPR- 3245	450(17.7)		500(19.6)	830(32.6)							122kg/ 269 lb
KPR- 3250	500(19.6)		550(21.6)	880(34.6)							135kg/ 297 lb
KPR- 3260	600(23.6)	400 (15.7)	650(25.5)	980(38.5)	60(2.36)	55(2.16)	145(5.70)	80(3.15)	16(0.62) × 6(0.23)	80mT (800G) 以上	140kg/ 308 lb
KPR- 3540C	400(15.7)		450(17.7)	790(31.1)							190kg/ 418 lb
KPR- 3545C	450(17.7)		500(19.6)	850(33.4)							210kg/ 463 lb
KPR- 3550C	500(19.6)	500 (19.6)	550(21.6)	900(35.4)	55(2.16)	50(1.96)	140(5.51)	70(2.75)	16(0.62) × 6(0.23)	80mT (800G) 以上	230kg/ 507 lb
KPR- 3560C	600(23.6)		650(25.5)	1000(39.3)							280kg/ 617 lb
KPR- 4045C	450(17.7)		500(19.6)	860(33.8)							270kg/ 595 lb
KPR- 4050C	500(19.6)	600 (23.6)	550(21.6)	920(36.2)	60(2.36)	55(2.16)	150(5.90)	90(3.54)	18(0.70) × 7(0.27)	300mT (3000G) 以上	300kg/ 661 lb
KPR- 4060C	600(23.6)		650(25.5)	1020(40.1)							355kg/ 782 lb
KPR- 4075C	750(29.5)		820(32.2)	1200(47.2)							450kg/ 992 lb
KPR- 5060C	600(23.6)	500 (19.6)	650(25.5)	1040(40.9)	70(2.75)	65(2.55)	150(5.90)	90(3.54)	18(0.70) × 7(0.27)	300mT (3000G) 以上	480kg/ 1058 lb
KPR- 5075C	750(29.5)		820(32.2)	1210(47.6)							630kg/ 1389 lb
KPR- 5090C	900(35.4)		1000(39.3)	1400(55.1)							750kg/ 1653 lb
KPR- 6075C	750(29.5)	600 (23.6)	820(32.2)	1300(51.1)	80(3.15)	75(2.95)	190(7.48)	100(3.93)	20(0.78) × 7.5(0.29)	300mT (3000G) 以上	900kg/ 1984 lb
KPR- 6090C	900(35.4)		1000(39.3)	1500(59.0)							1070kg/ 2359 lb
KPR-60105C	1050(41.3)		1150(45.2)	1670(65.7)							1230kg/ 2712 lb
KPR-60120C	1200(47.2)	750 (29.5)	1300(51.1)	1820(71.6)	90(3.54)	85(3.34)	200(7.87)	150(5.90)	25(0.98) × 9(0.35)	300mT (3000G) 以上	1450kg/ 3197 lb
KPR- 7575C	750(29.5)		820(32.2)	1370(53.9)							1900kg/ 4189 lb
KPR-75105C	1050(41.3)		1150(45.2)	1700(66.9)							1650kg/ 3638 lb
KPR-75120C	1200(47.2)	900 (35.4)	1300(51.1)	1950(76.7)	110(4.33)	95(3.74)	250(9.84)	200(7.87)	28(1.10) × 10(0.39)	300mT (3000G) 以上	1900kg/ 4189 lb
KPR-75140C	1400(55.1)		1500(59.0)	2150(84.6)							2150kg/ 4740 lb
KPR-90105C	1050(41.3)		1150(45.2)	1750(68.9)							125(4.92)
KPR-90120C	1200(47.2)	900 (35.4)	1300(51.1)	2000(78.7)	135(5.31)	110(4.33)	250(9.84)	250(9.84)	28(1.10) × 10(0.39)	300mT (3000G) 以上	2450kg/ 5401 lb
KPR-90140C	1400(55.1)		1500(59.0)	2350(92.5)							140(5.51)

**[Application]**  
These pulleys are utilized to remove iron as with electromagnet pulleys.

- [Features]**
- The powerful magnetic force and its effect last almost perpetually.
  - No power source is required to generate the magnetic force.
  - Robust construction and easy handling and installation
  - Max.Flux Density 0.5T(5000G)type(KPR-H2850,etc) is also available.

MAGNETIC TOOLS FOR WELDING OPERATION  
LIFTING MAGNET  
MAGBORE  
CHIP & SLUDGE TRANSPORTERS  
ENVIRONMENTAL EQUIPMENT  
MAGNETIZERS AND DEMAGNETIZERS  
MAGNETIC EQUIPMENT FOR TRANSPORTATION  
MAGNETIC SEPARATORS  
HIGH-GRADE MAGNETIC SEPARATORS  
MEASURING TOOLS  
MAGNETIC MATERIALS