

# HIGH GRADE MAGNETIC SEPARATORS

## Model PCMS SANITARY TYPE MAGNETIC FILTER (STRAIGHT TYPE)

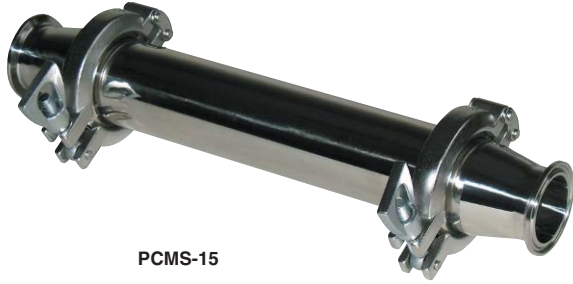

PCMS-15

### [Features]

- Recommended where the amount (flow rate) of materials to process is small.
- Simple construction for easy overhaul and cleaning.
- Compact and light weight, requiring little space.
- An example of application: Mayonnaise, steak, paste

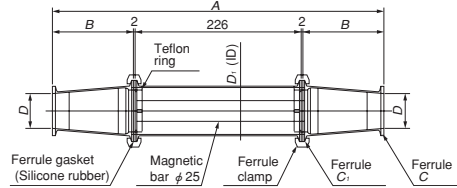

### Powerful type / Heat-resistant powerful type / Super powerful type

[mm (in)]

Powerful type	Model			Surface Material	Surface Finish	Working Pressure Limit	External Dimensions					Working Temperature			Mass
	Heat-resistant powerful type	Super powerful type	Super powerful type				A	B	C	C <sub>1</sub>	D	D <sub>1</sub>	Powerful type	Heat-resistant powerful type	
PCMS-10	PCMS-T10	PCMS-A10	SUS304	# 400 buffed	500kPa (5kgf/cm <sup>2</sup> )	340 (13.3)	55 (2.16)	1S	2S	φ 23 (0.90)	φ 47.8 (1.88)	Upper limit			Approx. 2.5kg/5.51 lb
PCMS-15	PCMS-T15	PCMS-A15				1.5S	2S	φ 35.7 (1.41)	φ 47.8 (1.88)	80°C (176° F)					
PCMS-20	PCMS-T20	PCMS-A20				2S	2.5S	φ 47.8 (1.88)	φ 59.5 (2.34)	150°C (302° F)					
											0.8T (8000G) min	0.8T (8000G) min	1T (10000G) min	Approx. 3.0kg/6.61 lb	

## Model PCMY SANITARY TYPE MAGNETIC FILTER FOR LIQUID

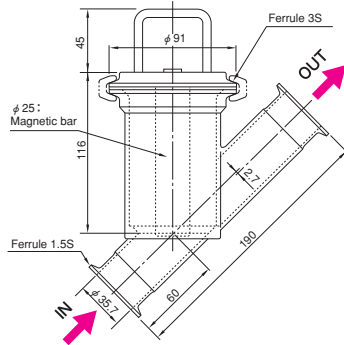

### [Features]

- A Y type filter for use with straight piping. The magnetic bar can be cleaned easily.
- An example of application: Noodle soup, sauce, syrup

Model	Surface Material	Surface Finish	Surface Max. Magnetic Flux Density	Working Temperature	Load Resistance	Mass
PCMY-15	SUS304	# 400 buffed	0.8T (8000G) min	Upper limit 80°C (176° F)	1,000kPa (10kgf/cm <sup>2</sup> )	Approx. 4kg/8.8 lb
PCMY-T15				Upper limit 150°C (302° F)		

## Model CPM TUBULAR TYPE MAGNETIC SEPARATOR



CPM-10

### CPM sanitary specification

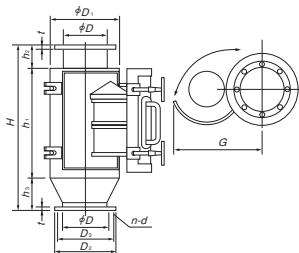
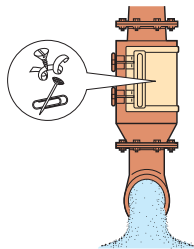

### [Application]

A tubular separator incorporating a powerful columnar permanent magnet. When this separator is installed in a system to flow such nonmagnetic substances as powder and bulk materials, mixed iron pieces, etc. can be removed. This separator has a construction suitable for vertical falling flow operations.

### [Features]

- Eight models are available by cylinder sizes to meet various mounting shapes.
- The magnet is housed in a robust steel tube for protection against impacts by powder and bulk materials.
- The opening hatch facilitates removal of iron pieces.
- While the iron-removal rate is very high, the installation cost is low and almost no running cost is required.
- The transfer line and processing equipment are protected against damage by iron pieces.
- Possible spark formation of powder and bulk materials can be prevented.
- The quality and purity can be increased and reliability can be enhanced.

[mm (in)]

Model	Flow Capacity	External Dimensions										Mass	
		φ D	φ D <sub>1</sub>	H	h <sub>1</sub>	h <sub>2</sub>	h <sub>3</sub>	φ D <sub>2</sub>	D <sub>3</sub>	n-d	t		G
CPM-5	1 m <sup>3</sup> /h	61 (2.40)	145 (5.70)	310 (12.2)	195 (7.67)	50 (1.96)	65 (2.55)	130 (5.11)	105 (4.13)	6 (0.23) - φ 10 (0.39)	8 (0.31)	200 (7.87)	6kg/13 lb
CPM-10	2.5m <sup>3</sup> /h	102 (4.01)	220 (8.66)	570 (22.4)	370 (14.5)	70 (2.75)	130 (5.11)	190 (7.48)	155 (6.10)			300 (11.8)	12.5kg/28 lb
CPM-15	6 m <sup>3</sup> /h	165 (6.49)	275 (10.8)	680 (26.7)	430 (16.9)	100 (3.93)	150 (5.90)	265 (10.4)	230 (9.05)	8 (0.31) - φ 10 (0.39)	8 (0.31)	310 (12.2)	22kg/48 lb
CPM-20	10 m <sup>3</sup> /h	216 (8.50)	345 (13.5)	790 (31.1)	520 (20.4)		170 (6.69)	320 (12.6)	280 (11.0)			390 (15.3)	30kg/66 lb
CPM-25	15 m <sup>3</sup> /h	267 (10.5)	435 (17.1)	950 (37.4)	580 (22.8)		270 (10.6)	385 (15.2)	345 (13.5)			485 (19.1)	45kg/99 lb
CPM-30	20 m <sup>3</sup> /h	319 (12.5)	485 (19.1)	1000 (39.3)	600 (23.6)	300 (11.8)	430 (16.9)	390 (15.3)	2 (0.47) - φ 14 (0.55)	8 (0.31)	560 (22.0)	58kg/127 lb	
CPM-40	35 m <sup>3</sup> /h	406 (15.9)	620 (24.4)	1100 (43.3)	700 (27.5)		540 (21.2)	495 (19.4)			715 (28.2)	85kg/187 lb	
CPM-50	55 m <sup>3</sup> /h	508 (20.0)	780 (30.7)	1200 (47.2)	780 (30.7)	320 (12.6)	655 (25.7)	605 (23.8)	885 (34.8)	110kg/242 lb			

\*A sanitary spec version is also available upon request.

MAGNETIC TOOLS FOR WELDING OPERATION  
 LIFTING MAGNET  
 MAGBORO  
 CHIP & SLUDGE TRANSPORTERS  
 ENVIRONMENTAL EQUIPMENT  
 MAGNETIZERS AND DEMAGNETIZERS  
 MAGNETIC EQUIPMENT FOR TRANSPORTATION  
 MAGNETIC SEPARATORS  
 HIGH GRADE MAGNETIC SEPARATORS  
 MEASURING TOOLS  
 MEASURING INSTRUMENTS  
 MAGNETIC MATERIALS