

## Model MMZ MAGNETIC MINI CHUCK

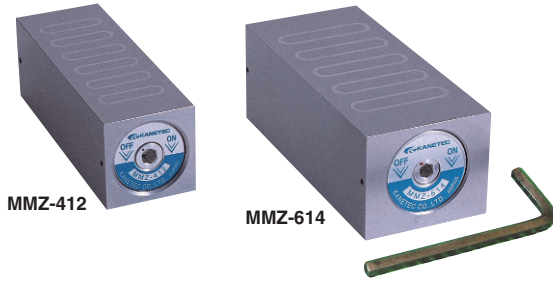

### [Application]

These chucks are used in combination with a magnetic chuck as an auxiliary holding tool for irregular-shaped workpieces in grinding and lightduty cutting. They are of waterproof construction enabling them to hold workpieces in electric discharge machining fluid.

### [Features]

- The magnetic force can be turned ON and OFF from either the front side or the rear side.
- The waterproof construction allows use in fluid.

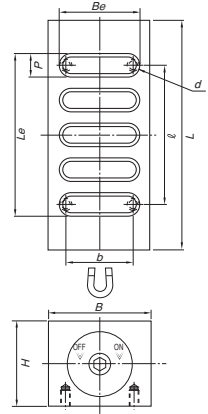

Model	Holding Power	Holding Face				Pole Pitch P	Mounting Face			Height H	Handle Hole	Mass
		B	L	Be	Le		b	ℓ	d			
MMZ-412	105N (10.5kgf)	40 (1.57)	115 (4.52)	29 (1.14)	84 (3.30)	7.5 (1.5+6) 0.29 (0.05+0.23)	30 (1.18)	75 (2.95)	4-M5 (0.19) depth 7 (0.27)	40 (1.57)	Nominal 6 (0.23)	1.3kg/2.8 lb
MMZ-614	400N (40kgf)	60 (2.36)	135 (5.31)	47 (1.85)	92 (3.62)	10 (2 +8) 0.39 (0.07+0.31)	40 (1.57)	80 (3.15)	4-M6 (0.23) depth 10 (0.39)	50 (1.96)		3.1kg/6.8 lb

※ The holding power is based on a test piece of □50 x 125, S15C.

## Model MMC MAGNETIC MINI CHUCK

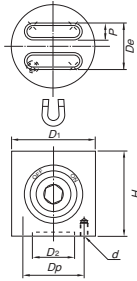
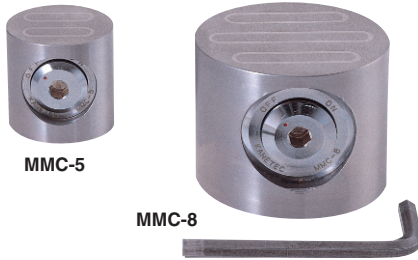

### [Application]

These chucks are used in combination with a magnetic chuck as an auxiliary holding tool for irregular-shaped workpieces in grinding and lightduty cutting. They can also be used for such applications as holding workpieces in advance to reduce the set-up time. Thus they can be used for continuous grinding of small and thin workpieces.

### [Features]

- These chucks are powerful with special construction using Alnico magnet steel.
- Although small, these chucks have an ON / OFF mechanism.

Model	Holding Power	Holding Face		Pole Pitch P	Mounting Face			Height H	Handle Hole	Mass
		D <sub>1</sub>	D <sub>e</sub>		D <sub>p</sub>	D <sub>2</sub>	d			
MMC-5	85N (8.5kgf)	50 (1.96)	29 (1.14)	9.5 (1.5+8) 0.37 (0.06+0.31)	35 (1.37)	25 (0.98)	4-M5 (0.19) depth 7 (0.27)	50 (1.96)	Nominal 8 (0.31)	0.7kg/1.5 lb
MMC-8	500N (50kgf)	80 (3.15)	54 (2.12)	10 (2 +8) 0.39 (0.08+0.31)	60 (2.36)	50 (1.96)	4-M6 (0.23) depth 10 (0.39)	65 (2.55)		2.2kg/4.8 lb

※ The holding power is based on a test piece of □50 x 125, S15C.

## Model MMW MAGNETIC MINI CHUCK

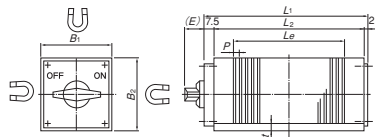
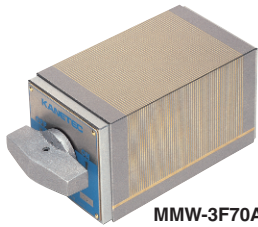

### [Application]

These chucks have three attractive faces and can be used in combination with a magnetic chuck. They are suitable for determining angles of small workpieces and angle grinding.

### [Features]

- Since these chucks have three attractive faces, one face may be used for mounting the chuck and other faces for holding workpieces.
- They have magnetic poles arranged at micro pitches to hold small workpieces.
- They are of waterproof construction.

Model	Nominal Dimension	Holding Power	Dimensions							Pole Pitch P	Squareness	Flatness	Mass
			B <sub>1</sub>	B <sub>2</sub>	L <sub>1</sub>	L <sub>2</sub>	E	Le	t				
MMW-3F50A	55 (2.16) × 115 (4.52)	600N (60kgf)	55 (2.16)	55 (2.16)	125.5	115	20.5 (0.80)	90.5	10	1.5 (0.5+1.0)	0.01	0.02	2.8kg/6.2 lb
MMW-3F70A	70 (2.75) × 115 (4.52)	900N (90kgf)	70 (2.75)	70 (2.75)	(4.94)	(4.52)	25.5 (1.00)	(3.56)	(0.39)	0.05 (0.02+0.03)			4.0kg/8.8 lb

※ The holding power is based on a test piece of □50 x 125, S15C, ground surface, with nothing held on other faces.

## Model MMXW MAGNETIC MINI CHUCK

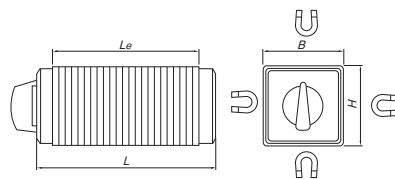
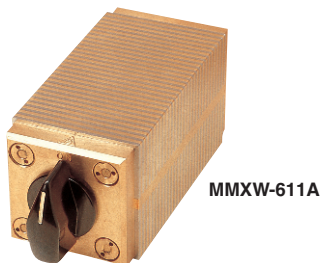

### [Application]

These chucks are suitable for holding workpieces in such processes as grinding, boring, cutting, electric discharge machining, welding and assembly. Since four faces can hold workpieces simultaneously, they can be used as a magnet vice in a wide range of applications.

### [Features]

- These are unique universal mini chucks capable of holding work-pieces on four faces.
- They can be used in such a way as to hold workpieces on the bed of machine tools or holding workpieces on the top and side faces simultaneously. They can also be used as a guide stopper to secure workpieces.
- The accuracy is as follows: flatness 0.01 mm, parallelism 0.02 mm, perpendicularity 0.03 mm.

Model	Holding Power		Dimensions			Pole Pitch P	Height H	Mass
	Two Face Holding	Full Face Holding	B	Le	L			
MMXW-611A	400N (40kgf) or over	60N (6kgf) or over	64 (2.52)	112 (4.40)	136 (5.35)	4 (2+2) 0.15 (0.07+0.07)	64 (2.52)	3.5kg/ 7.7 lb

※ The holding power is based on a test piece of □50 x 125, S15C, ground surface, with nothing held on other faces.

ELECTROMAGNETIC CHUCKS  
CHUCK CONTROLLERS  
PERMANENT MAGNETIC CHUCKS  
PERMANENT ELECTROMAGNETIC CHUCKS  
BLOCKS FOR MC  
VACUUM CHUCKS  
PROMELTA SYSTEM  
SINE BAR CHUCKS  
MAGNETIC BLOCKS  
WORKING TOOLS  
MEASURING TOOL HOLDERS  
MAGNETIC HOLDERS  
MAGNETIC TOOLS

## Model RMAW-2F BLOCK WITH 2 ATTRACTIVE FACES FOR SMALL SIZE WORK PIECES

The strongest type of block is provided with 2 faces attractive face.



**NEW**

RMAW-2F0812

**[Application]**

It can be used for processing from grinding to milling, holding work during various measuring, assembling work.

**[Features]**

- The strongest attractive force among small permanent magnet type. Furthermore, by making pole pitch thinner, its power is concentrated to attract small and thin work pieces. It is effective for relatively larger work pieces or attracting the whole face, too.
- The upper and bottom magnetic face can be changed independently. It can be set easily onto machine table or working table for fast set up and removal.
- Because a work piece can be attracted on its side face, work pieces can be fixed vertically, or on 3 faces.
  - ※ In case a work piece is fixed on upper or bottom face and side faces at the same time, each attractive force is reduced.
- By using screw holes on 3 side faces or bottom face, such attachment as a stopper or a jig can be installed.

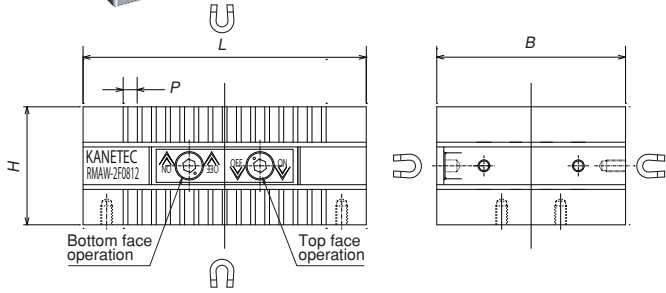

Model	Holding Power	Dimensions			Pole Pitch	Mass
		B	L	H	P	
RMAW-2F0812	785N (80kgf)	80 (3.15)	120 (4.72)	50 (1.96)	6(2+4) 0.23(0.07+0.15)	3.7kg 8.15 lb

※ The holding power is based on a test piece of □50 x t25, S15C.

## Model KPB MAGNETIC BLOCK



KPB-1F18



KPB-2F18

**[Application]**

These blocks can hold workpieces during electric discharge machining, wire cutting and grinding.

They can be used as holding tools for assembly and light-duty machining.

**[Features]**

- The both sides can hold workpieces and can be turned ON and OFF individually. (2F models)
- They are secured to the worktable by turning ON and OFF the magnet. (2F models)
- The side faces (ON/OFF select faces) can also hold workpieces. (2F models)
- They are secured to the worktable using tapped holes provided on the mounting face. They can also be secured by having them held by a magnet chuck. (1F model)
- The operating areas are provided on both side faces to facilitate ON/OFF operation.
- Light weight for easy positional adjustment.
- The operating handle is removal and will not hinder the work.
- One set of two blocks has been machined and finished together.
- They are of waterproof and oilproof construction to allow them to be used in fluid.

An example of usage of double-face attracting block

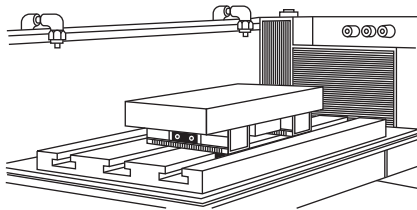

<Model KPB-1F dimensions>

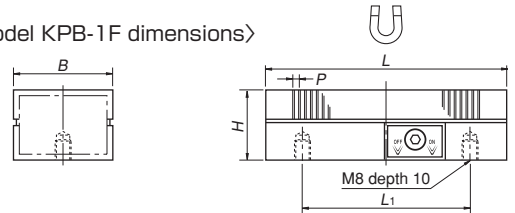

<Model KPB-2F dimensions>

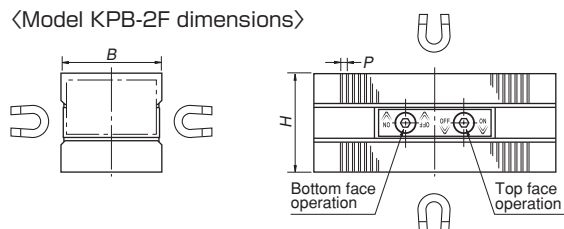

### Single face type 1F model

Model	Nominal Dimension	Holding Power	Dimensions				Pole Pitch	Mass
			B	L	H	L <sub>1</sub>	P	
KPB-1F13	50 (1.96) × 125 (4.92)	250N (25kgf)	52	125 (4.92)	35	85 (3.34)	1.5 (0.5+1.0)	1.5kg / 3.3 lb × 2
KPB-1F18	50 (1.96) × 180 (7.08)	350N (35kgf)	(2.04)	180 (7.08)	(1.37)	110 (4.33)	0.05 (0.02+0.03)	2.2kg / 4.8 lb × 2
KPB-1F25	50 (1.96) × 250 (9.84)	500N (50kgf)		250 (9.84)		150 (5.90)		3.1kg / 6.8 lb × 2

### Dual face type 2F model

Model	Nominal Dimension	Holding Power	Dimensions				Pole Pitch	Mass
			B	L	H	P		
KPB-2F13	50 (1.96) × 125 (4.92)	250N (25kgf)	52	125 (4.92)	50	85 (3.34)	1.5 (0.5+1.0)	2.5kg / 5.5 lb × 2
KPB-2F18	50 (1.96) × 180 (7.08)	350N (35kgf)	(2.04)	180 (7.08)	(1.37)	110 (4.33)	0.05 (0.02+0.03)	3.6kg / 8.0 lb × 2
KPB-2F25	50 (1.96) × 250 (9.84)	500N (50kgf)		250 (9.84)		150 (5.90)		5.0kg / 11.1 lb × 2

※ The holding power is when they hold an SS400, 20-mm thick workpiece (ground surface) over the whole area.

ELECTROMAGNETIC CHUCK CONTROLLERS PERMANENT MAGNETIC CHUCKS PERMANENT MAGNETIC CHUCKS FOR MC VACUUM CHUCKS PROMELTA SYSTEM SINE BAR CHUCKS MAGNETIC BLOCKS WORKING TOOLS MEASURING TOOL HOLDERS MAGNETIC HOLDERS MAGNETIC TOOLS

Model **KM-JB** SWITCHABLE PERMANENT MAGNETIC HOLDER

suitable as exclusive fixing jig for round steel of extra-ordinary shape of work pieces!



[Application]

In addition to using it as a fixing device for small work pieces, it can be used as a block to support 3 parts of a work piece during grinding.

[Features]

- Holes can be made down to 10mm additionally on each face. (Except the face for on/off operation and rear face)
- By using it as exclusive jig to a particular work piece, working performance is improved.
- Due to its drip-proof structure, it can be used in liquid such as ED processing.

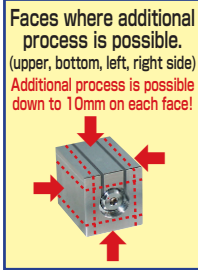

※However, please avoid making a hole on the part of pin and counter-bore.

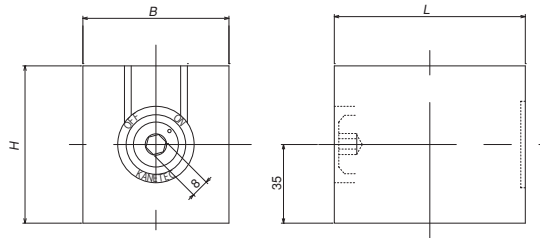
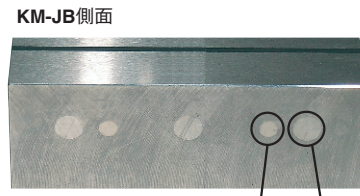

Model	Holding Power	Dimensions			Mass
		B	L	H	
KM-JB0709	392N (40kgf)	65 (2.55)	85 (3.34)	70 (2.75)	2.5kg/ 5.5 lb
KM-JB0812	883N (90kgf)	80 (3.14)	120 (4.72)	90 (3.54)	5.5kg/ 12.1 lb

※The holding power is based on a test piece of □50 x t25, S15C.  
※The handle is a hexagonal wrench key.

Model **MM** FREE BLOCK

Freely workable permanent magnetic blocks

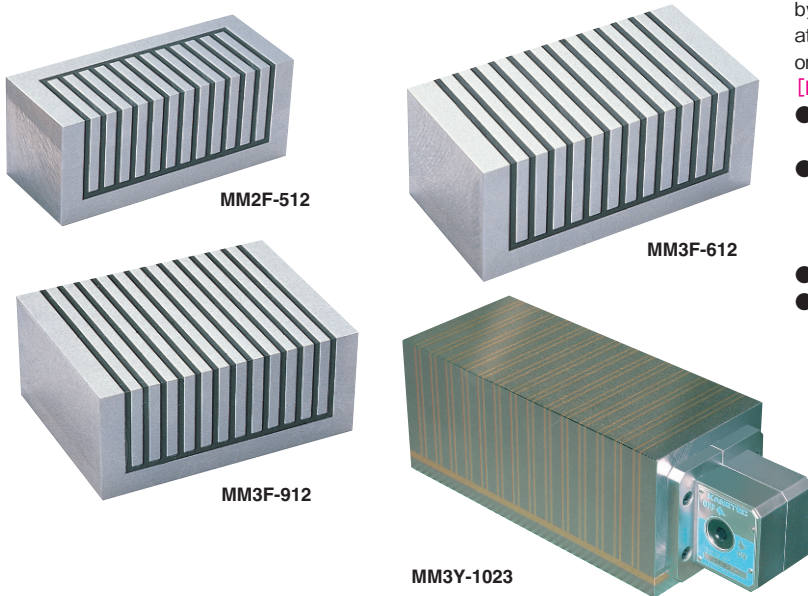

[Application]

These blocks are designed to allow deep engraving (machining by customer) such as grooves and steps on the magnetic attractive face to fit workpiece shapes when holding workpieces on these MM models.

[Features]

- The attractive face can be removed up to 10 mm deep from the surface of new blocks.
- As workpieces can be fitted in grooves, a large machining pressure can be used. Also cemented carbide workpieces, which are difficult to hold, can be held by using these blocks uniquely to enable grinding.
- These blocks can be mounted on the magnetic chuck work face.
- There are two types; a magnetic force ON-OFF type and a type not equipped with ON-OFF function.

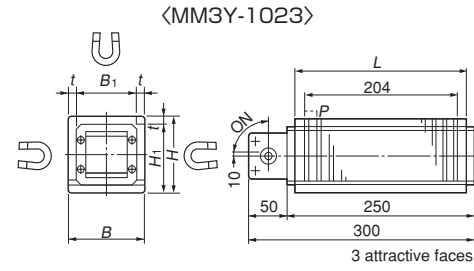
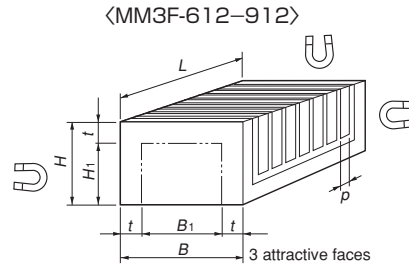
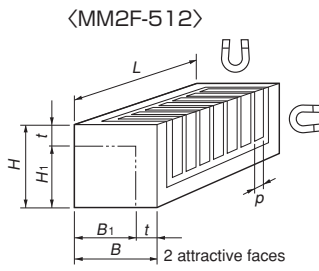
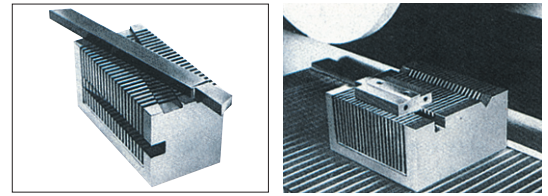

Model	Nominal Dimensions	Holding Power	Dimensions					Pole Pitch P	Work Area t	ON/OFF	Mass
			B	L	H	B <sub>1</sub>	H <sub>1</sub>				
MM2F- 512	50 (1.96) × 120 (4.72)	200N (20kgf)	50 (1.96)	120 (4.72)	50 (1.96)	40 (1.57)	8 (3+5) 0.31 (0.11+0.19)	Max.10 (0.39)	None	2kg/ 4.4 lb	
MM3F- 612	60 (2.36) × 120 (4.72)	400N (40kgf)	60 (2.36)		40 (1.57)	2.5kg/ 5.5 lb					
MM3F- 912	90 (3.54) × 120 (4.72)	600N (60kgf)	90 (3.54)		70 (2.75)	3.5kg/ 7.7 lb					
MM3Y-1023	100 (3.93) × 230 (9.05)	750N (75kgf)	100 (3.93)	230 (9.05)	100 (3.93)	80 (3.15)	90 (3.54)	15.2 (0.59)	Provided	20kg/ 44 lb	

※The holding power applies to S15C, □50 x t25, ground surface and is presented for reference only.

ELECTROMAGNETIC CHUCKS  
CHUCK CONTROLLERS  
PERMANENT MAGNETIC CHUCKS  
PERMANENT ELECTROMAGNETIC CHUCKS  
BLOCKS FOR MC  
VACUUM CHUCKS  
PROMELTA SYSTEM  
SINE BAR CHUCKS  
MAGNETIC BLOCKS  
WORKING TOOLS  
MEASURING TOOL HOLDERS  
MAGNETIC HOLDERS  
MAGNETIC TOOLS



## Model KYA SQUARE TYPE BLOCK

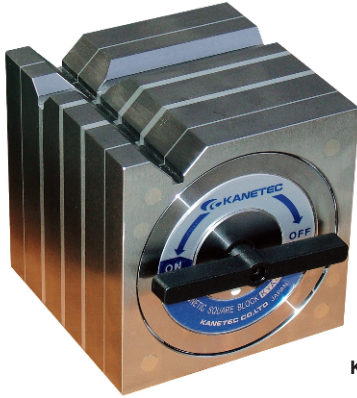

KYA-13B

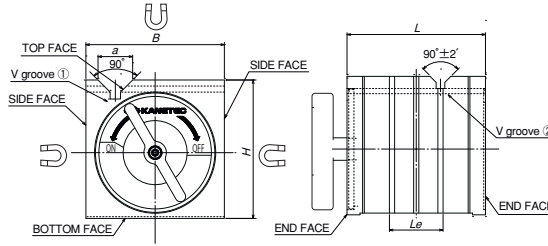

### [Application]

Holding tools for marking and light duty machining.  
Holding tools for electric discharge machining and wire cutting.  
Holding tools for three-dimensional measuring instruments and various measuring systems.

### [Features]

- Workpieces can be held on three faces of top (V face) and both side faces.
- On/Off lever is detachable. (length of each opposite side of hexagonal hole is 8mm)
- They are of waterproof and oilproof construction.
- An M8 tapped hole is provided on the top for lifting (KYA-18 only).
- Super high accuracy finish is also available. Please contact us.

[mm(in)]

Model	Holding Power		Applicable Diameter		Dimensions					Mass
	V groove①	V groove②	V groove①	V groove②	B	H	L	Le	a	
KYA-8B	120N (12kgf)	100N (10kgf)	φ10~φ25	φ8~φ15	80(3.14)	80(3.14)	80(3.14)	31(1.22)	20(0.78)	3.5kg/ 7.7 lb
KYA-10B	200N (20kgf)	120N (12kgf)	φ10~φ35	φ10~φ30	100(3.93)	100(3.93)	100(3.93)	42(1.65)	26(1.02)	7kg/ 15 lb
KYA-13B	300N (30kgf)	250N (25kgf)	φ10~φ40	φ10~φ26	125(4.92)	125(4.92)	125(4.92)	48(1.88)	30(1.18)	14kg/ 30 lb
KYA-15B	400N (40kgf)	400N (40kgf)		φ10~φ38	150(5.90)	150(5.90)	150(5.90)	61(2.40)	32(1.25)	23kg/ 13 lb
KYA-18B		300N (30kgf)	φ14~φ50	φ14~φ50	180(7.08)	180(7.08)	180(7.08)	69(2.71)	38(1.49)	37kg/ 13 lb
KYA-20B	650N (65kgf)	650N (65kgf)		φ14~φ50	200(7.87)	200(7.87)	200(7.87)	101(3.97)		51kg/ 112 lb

※ The above value attractive force is in case of round steel of dia. 20mm on V face.

※ For accuracy, please refer to the below-mentioned table.

※ Please take note that attractive force of the each face is reduced when a work piece is attracted on more than 2 faces at the same time.

### KYA Block/holder accuracy

(μm)

Item	Model /Accuracy	KYA-8B		KYA-10B		KYA-13B		KYA-15B		KYA-18B		KYA-20B	
		Standard	Special	Standard	Special	Standard	Special	Standard	Special	Standard	Special	Standard	Special
Parallelism	Bottom face to top face					15		15		20		20	
	Bottom face to V face	10		10									
	End face to end face		7		7	12	8	12	8	15	9	15	9
	Side face to V face	20		20		25		25		30		30	
Flatness of bottom face		10		10		15		15		20		20	
Squareness	Bottom face to side face	20	10	20	10	25	12	25	12	30	14	30	14

## Model KYB SQUARE TYPE BLOCK



KYB-13A

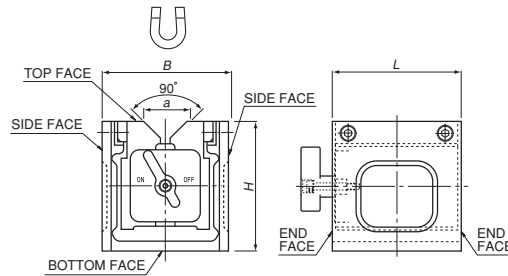

### [Application]

- Holding device for marking or light processing.
- Holding device for ED process
- Holding device for three dimensional measuring machine and various kinds of measuring, measuring system.

### [Features]

- The attraction on one face of the upper (V) face is possible.
- On/Off lever is detachable. (length of each opposite side of hexagonal hole is 8mm)
- Drip-proof and oil resistance type,
- The higher accuracy finish is separately available upon request.

[mm(in)]

Model	Holding Power	Applicable Diameter	Dimensions				Mass
			B	H	L	a	
KYB-8A	180N (18kgf) or over	φ10~φ32	80(3.14)	80(3.14)	80(3.14)	29(1.02)	2.5kg/5.5 lb
KYB-10A	343N (35kgf) or over	φ13~φ50	100(3.93)	100(3.93)	100(3.93)	40(1.57)	6kg/13 lb
KYB-13A	400N (40kgf) or over		125(4.92)	125(4.92)	125(4.92)		8kg/17 lb
KYB-15A	589N (60kgf) or over	φ14~φ66	150(5.90)	150(5.90)	150(5.90)	50(1.96)	12kg/26 lb
KYB-18A	600N (60kgf) or over		180(7.08)	180(7.08)	180(7.08)		16kg/35 lb
KYB-20A	785N (80kgf) or over		200(7.87)	200(7.87)	200(7.87)		22kg/48 lb

### KYB Block/holder accuracy

※ The holding power applies to the V-face and φ20 round bar. ※ For accuracy, see the table below.

(μm)

Item	Model /Accuracy	KYB-8A		KYB-10A		KYB-13A		KYB-15A		KYB-18A		KYB-20A	
		Standard	Special	Standard	Special	Standard	Special	Standard	Special	Standard	Special	Standard	Special
Parallelism	Bottom face to top face					15		15		20		20	
	Bottom face to V face	10		10									
	End face to end face		7		7	12	8	12	8	15	9	15	9
	Side face to V face	20		20		25		25		30		30	
Flatness of bottom face		10		10		15		15		20		20	
Squareness	Bottom face to side face	20	10	20	10	25	12	25	12	30	14	30	14



Model **KVA** MAGNETIC V-HOLDER

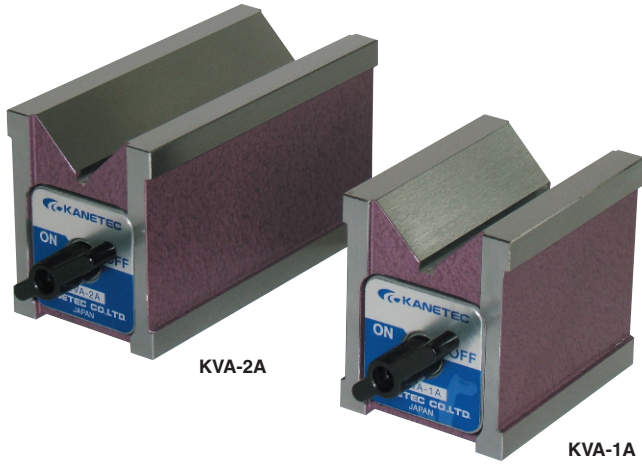

[Application]

Holding tools for round bar marking, drilling, tapping and grinding of irregular-shaped workpieces.  
 Holding tools for electric discharge machining and wire cutting.  
 Holding tools for three-dimensional measuring instruments and various measuring systems.

[Features]

- Workpieces can be held on the top face (V face), bottom face, and rear face.
- T-handle ON/OFF switch comes attached, but can be removed.
- They are of waterproof and oilproof construction.
- Super high accuracy finish is also available. Please contact us.

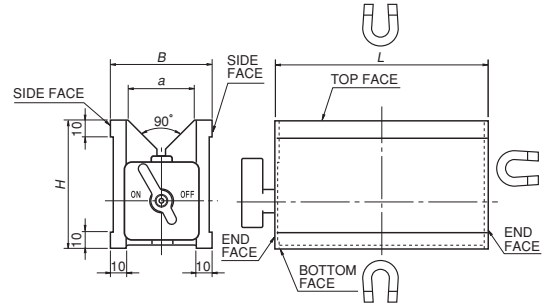

[mm(in)]

Model	Holding Power	Applicable Diameter	Dimensions				Mass
			B	H	L	a	
KVA-1A	300N (30kgf) or over	φ8~φ50	60 (2.36)	73 (2.87)	80 (3.14)	38 (1.49)	2kg/4.4 lb
KVA-2A	450N (45kgf) or over				125 (4.92)		3kg/6.6 lb
KVA-3A	700N (70kgf) or over				180 (7.08)		4.5kg/10 lb

※ The holding power applies to the V-face and φ20 round bar. ※For accuracy, see the table below.

Model **KVA-2F** MAGNETIC V-HOLDER

The first release in this design!!

On/Off switching of upper and bottom face is possible independently.



An example of mounting

[Application]

to be used in a wide range application as holding device from marking on round bar to milling.  
 It is used as a holding device for measuring work on iron surface tables.

[Features]

- Work piece can be held and removed without changing fixed holding position. Working can be done effectively.
- On/Off lever is detachable. ( length of each opposite side of hexagonal hole is 8mm )
- Drip-proof and oil resistance structure
- Higher accuracy finish is available.

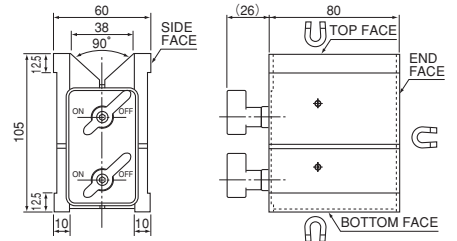

[mm (in)]

Model	Holding Power	Applicable Diameter	Dimensions			Mass
			Width	Height	Length	
KVA-2F1A	392N (40kgf) or over	φ8~φ50	60 (2.36)	105 (4.13)	80 (3.14)	3.2kg/7.0 lb

※ The holding power applies to the V-face and φ20 round bar. ※For accuracy, see the table below

■ KVA Block/holder accuracy

(μm)

Model /Accuracy		KVA-1A		KVA-2A		KVA-3A		KVA-2F1A	
Item		Standard	Special	Standard	Special	Standard	Special	Standard	Special
Parallelism	Bottom face to top face	10	7	15	8	20	9	10	7
	Bottom face to V face			12		15			
	End face to end face			25		30			
	Side face to V face			20		20			
Flatness of bottom face		10		15		20		10	
Squareness	Bottom face to side face	20	10	25	12	30	14	20	10

ELECTROMAGNETIC CHUCKS  
 CHUCK CONTROLLERS  
 PERMANENT MAGNETIC CHUCKS  
 PERMANENT ELECTROMAGNETIC CHUCKS  
 BLOCKS FOR MC  
 VACUUM CHUCKS  
 PROMELTA SYSTEM  
 SINE BAR CHUCKS  
 MAGNETIC BLOCKS  
 WORKING TOOLS  
 MEASURING TOOL HOLDERS  
 MAGNETIC HOLDERS  
 MAGNETIC TOOLS

## Model KVS MAGNETIC V-HOLDER

ELECTROMAGNETIC CHUCK  
ELECTROMAGNETIC CHUCK CONTROLLERS  
PERMANENT MAGNETIC CHUCKS  
PERMANENT MAGNETIC CHUCKS

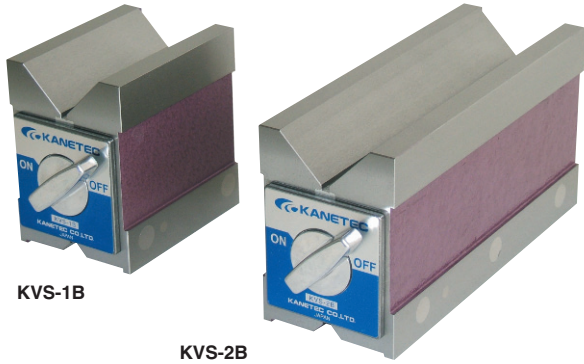

### [Application]

It is to be used to fix such extra-ordinary shape work pieces under grinding, light milling for making holes and tapping.

### [Features]

- The strong magnetic force works three faces of upper, bottom, edge ( or, shorter side) by special structure.
- It can be used for inspection work. Standard and special class accuracy are available.
- As on/off operation of magnetic force can be easily done by switching lever.
- Drip-proof.

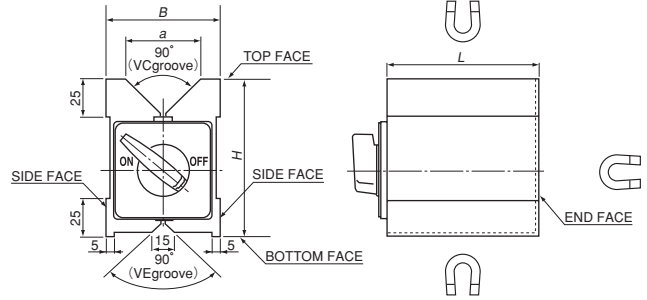

Model	Holding Power	Applicable Diameter		Dimensions				Mass
		Round Steel	VC groove	VE groove	B	a	L	
KVS-1B	0.7kN (70kgf)	φ8 (0.31) ~	φ8 (0.31) ~	75	50	100 (3.93)	105	4.5kg/ 9.9 lb
KVS-2B	1.0kN (100kgf)	φ68 (2.67)	φ20 (0.78)	(2.95)	(1.96)	200 (7.87)	(4.13)	9.0kg/ 19.8 lb

※ The holding power applies to the V-face and φ20 round bar. ※ For accuracy, see the table below.  
※ Please take note that attractive force on each face is reduced when a work piece is attracted on more than 2 faces at the same time.

BLOCKS FOR MC  
VACUUM CHUCKS

### KVS accuracy

Model / Accuracy		KVS-1B		KVS-2B	
		Standard	Special	Standard	Special
Parallelism	Bottom face to top face	12	7	20	12
	top face to VC groove				
	top face to VE groove				
	side face to side face				
Squareness	Bottom face to side face	21	10	21	15

(μm)

## Model KMV MAGNETIC V-BLOCK

PROMELTA SYSTEM  
SINE BAR CHUCKS  
MAGNETIC BLOCKS  
WORKING TOOLS  
MEASURING TOOL HOLDERS  
MAGNETIC HOLDERS  
MAGNETIC TOOLS



### [Application]

Holding tools for round bar marking and drilling.  
Holding tools for electric discharge machining and wire cutting.  
Holding tools for three-dimensional measuring instruments and various measuring systems.

### [Features]

- Workpieces can be held on the top face (V face), and rear face.
- T-handle ON/OFF switch comes attached, but can be removed.
- They are of waterproof and oilproof construction.
- One set consists of two blocks.
- Super high accuracy finish is also available. Please contact us.

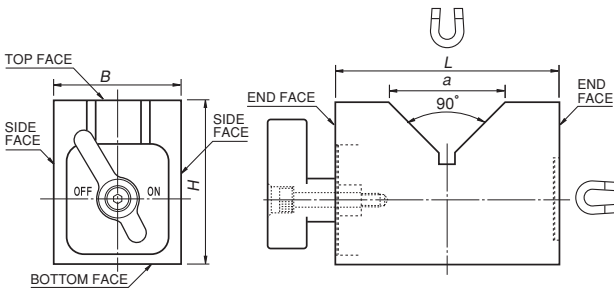

Model	Holding Power	Applicable Diameter	Dimensions				Mass
			B	H	L	a	
KMV- 50D	150N (15kgf) or over	φ 50 (1.96)	40 (1.57)	50 (1.96)	70 (2.75)	36 (1.41)	1kg/ 2.2 lb × 2
KMV- 80D	200N (20kgf) or over	φ 80 (3.14)	50 (1.96)	80 (3.14)	100 (3.93)	60 (2.36)	3kg/ 6.6 lb × 2
KMV-125D	230N (23kgf) or over	φ 125 (4.92)		100 (3.93)	150 (5.90)	90 (3.54)	5kg/ 11 lb × 2

※ The holding power applies to the V-face and φ20 round bar. ※ For accuracy, see the table below.

### KMV accuracy

Model / Accuracy		KMV-50D		KMV-80D		KMV-125D	
		Standard	Special	Standard	Special	Standard	Special
Parallelism	Bottom face to top face	10	7	15	8	20	9
	Bottom face to V face						
	End face to end face						
	Side face to V face						
Flatness of bottom face		10		15		20	
Squareness	Bottom face to side face	20	10	25	12	30	14
Difference in height of V faces of a pair of blocks		7		8			

(μm)

※ When high accuracy is required, select "special" accuracy models.  
※ In case the value of accuracy, which is not mentioned in the above table, please request us.

■ The dimensional accuracy of KVS and KMV are based on Kanetec's in-house standard. When you need higher accuracy, please contact us.



Model **KMV-M** MAGNETIC MINI V-BLOCK

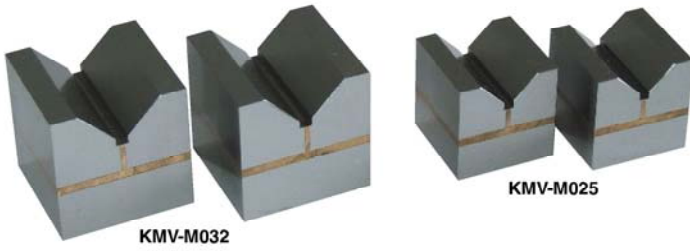

[Application]

These blocks are used to hold small diameter round bars on optical measuring equipment. (Non-waterproof type)

[Features]

- One set consists of two blocks. The attractive faces and other working faces have been machined accurately. The blocks can be turned ON and OFF by 90° turning using a screwdriver on the back.

Model	Holding Power	Applicable Diameter	Dimensions							Mass
			B	B <sub>1</sub>	B <sub>2</sub>	B <sub>3</sub>	H	L		
KMV-M020	9.8N (1kgf)	φ15 (0.59)	20 (0.78)	12 (0.47)	2.0 (0.07)	4 (0.15)	20 (0.78)	20 (0.78)	0.06kg/0.13 lb × 2	
KMV-M025	19.6N (2kgf)	φ20 (0.78)	25 (0.98)	15 (0.59)	2.5 (0.09)	5 (0.19)	25 (0.98)	25 (0.98)	0.13kg/0.28 lb × 2	
KMV-M032	49 N (5kgf)	φ25 (0.98)	32 (1.25)	20 (0.78)	3.0 (0.11)	6 (0.23)	32 (1.25)	32 (1.25)	0.24kg/0.53 lb × 2	

※ The holding power applies to round steel φ10.

■ The dimensional accuracy of KMV is based on Kanetec's in-house standard. When you need higher accuracy, please contact us.

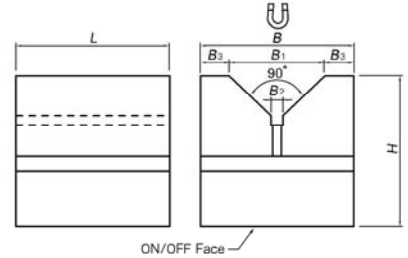

Model **KT-KTV** CHUCK BLOCK



[Application]

These blocks are used in combination with a magnetic chuck as an auxiliary tool to hold round bars and sheet-like workpieces that are difficult to hold on their side faces only by chucking.

[Features]

- Since these blocks are not magnetized themselves, they are placed on a magnetic chuck to induce magnetism to hold workpieces. Magnetism can be induced on two faces of top and side or V face and side.
- Specially-shaped workpieces can also be held by use of chuck blocks, thus making it possible to utilize your chucks in stock.
- One set of two blocks has been finished together. (KT-3 and -4 are available individually.)

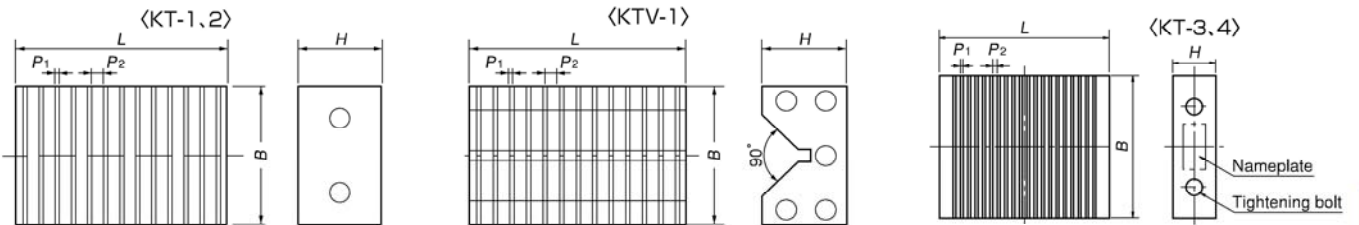

An example of usage

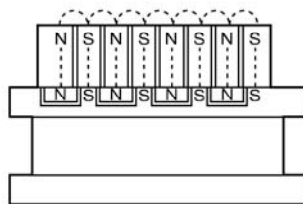

Model	Dimensions			Pole Pitch		Mass
	B	L	H	B <sub>1</sub>	B <sub>2</sub>	
KT-1	70 (2.75)	100 (3.93)	41 (1.61)	3.2 (0.12)	3.2 (0.12)	2.0kg/4.4 lb × 2
KT-2	45 (1.77)	72 (2.83)	22 (0.86)	3 (0.11)	3.2 (0.12)	0.37kg/0.8 lb × 2
KT-3	125 (4.92)	150 (5.90)	38 (1.49)	2 (0.07)	4.5 (0.17)	5.9kg/13 lb
KT-4	304 (11.9)	65 (2.55)	40 (1.57)	3 (0.11)	3.2 (0.12)	11.7kg/25 lb
KTV-1	60 (2.36)	65 (2.55)	40 (1.57)	3 (0.11)	3.2 (0.12)	0.78kg/1.7 lb × 2

※KTV-1 Applicable diameter to use: dia. 10 ~ 70mm

※In case of additional process, please inquire of us.

Model **MV** MINI V-ADAPTER

An example of usage

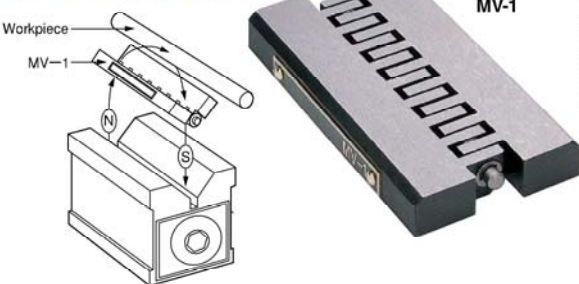

[Application]

This product itself is not magnetic, but when it is placed on a V-Holder having the N pole and S pole on separate sides like Model KVA, it induces magnetism to hold small diameter workpieces that can not be physically mounted directly. (See the figure below.) This adapter is recommended for holding workpieces during grinding, drilling and measurement.

[Features]

- The attractive faces can be set to any angle between 90 and 180 degrees.
- The hinge part acts as a separator to divide magnetic poles.

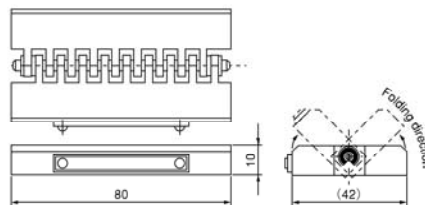

- Model: MV-1
- Dimensions: 80 × (42) × 10mm
- Parallelism: 0.006
- Hardened

ELECTROMAGNETIC CHUCKS  
CHUCK CONTROLLERS  
PERMANENT MAGNETIC CHUCKS  
PERMANENT ELECTROMAGNETIC CHUCKS  
BLOCKS FOR MC  
VACUUM CHUCKS  
PROMELTA SYSTEM  
SINE BAR CHUCKS  
MAGNETIC BLOCKS  
WORKING TOOLS  
MEASURING TOOL HOLDERS  
MAGNETIC HOLDERS  
MAGNETIC TOOLS