

Model **KVA** MAGNETIC V-HOLDER

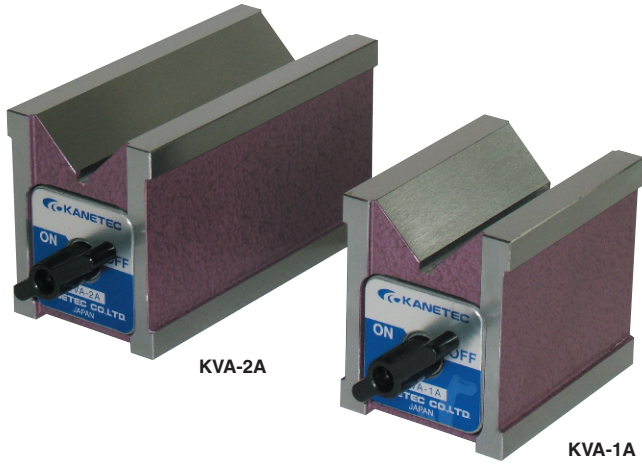

[Application]

Holding tools for round bar marking, drilling, tapping and grinding of irregular-shaped workpieces.  
 Holding tools for electric discharge machining and wire cutting.  
 Holding tools for three-dimensional measuring instruments and various measuring systems.

[Features]

- Workpieces can be held on the top face (V face), bottom face, and rear face.
- T-handle ON/OFF switch comes attached, but can be removed.
- They are of waterproof and oilproof construction.
- Super high accuracy finish is also available. Please contact us.

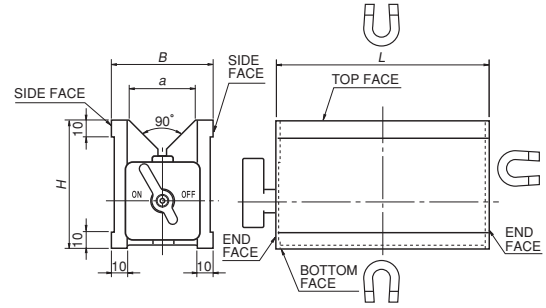

[mm(in)]

Model	Holding Power	Applicable Diameter	Dimensions				Mass
			B	H	L	a	
KVA-1A	300N (30kgf) or over	φ8~φ50	60 (2.36)	73 (2.87)	80 (3.14)	38 (1.49)	2kg/4.4 lb
KVA-2A	450N (45kgf) or over				125 (4.92)		3kg/6.6 lb
KVA-3A	700N (70kgf) or over				180 (7.08)		4.5kg/10 lb

※ The holding power applies to the V-face and φ20 round bar. ※For accuracy, see the table below.

Model **KVA-2F** MAGNETIC V-HOLDER

The first release in this design!!

On/Off switching of upper and bottom face is possible independently.

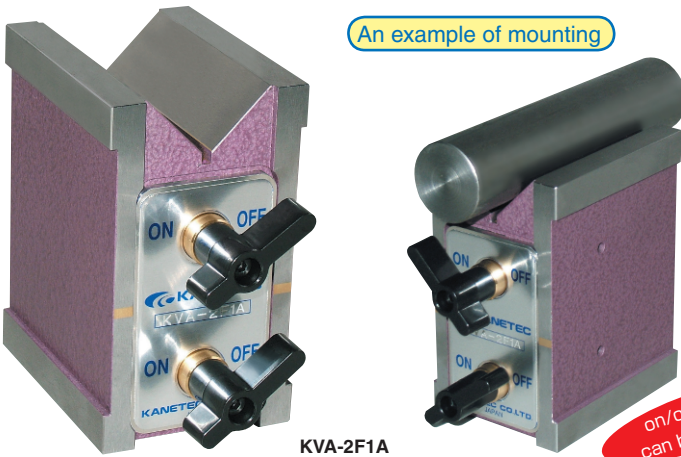

An example of mounting

[Application]

to be used in a wide range application as holding device from marking on round bar to milling.  
 It is used as a holding device for measuring work on iron surface tables.

[Features]

- Work piece can be held and removed without changing fixed holding position. Working can be done effectively.
- On/Off lever is detachable. ( length of each opposite side of hexagonal hole is 8mm )
- Drip-proof and oil resistance structure
- Higher accuracy finish is available.

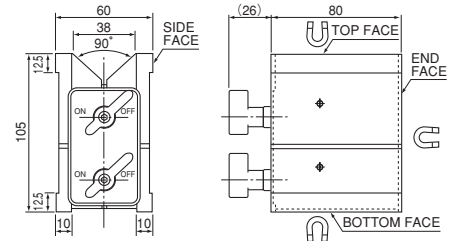

[mm (in)]

Model	Holding Power	Applicable Diameter	Dimensions			Mass
			Width	Height	Length	
KVA-2F1A	392N (40kgf) or over	φ8~φ50	60 (2.36)	105 (4.13)	80 (3.14)	3.2kg/7.0 lb

※ The holding power applies to the V-face and φ20 round bar. ※For accuracy, see the table below

■ KVA Block/holder accuracy

(μm)

Model /Accuracy		KVA-1A		KVA-2A		KVA-3A		KVA-2F1A	
Item		Standard	Special	Standard	Special	Standard	Special	Standard	Special
Parallelism	Bottom face to top face	10	7	15	8	20	9	10	7
	Bottom face to V face			12		15			
	End face to end face			25		30			
	Side face to V face			20		20			
Flatness of bottom face		10		15		20		10	
Squareness	Bottom face to side face	20	10	25	12	30	14	20	10

ELECTROMAGNETIC CHUCKS  
 CHUCK CONTROLLERS  
 PERMANENT MAGNETIC CHUCKS  
 PERMANENT ELECTROMAGNETIC CHUCKS  
 BLOCKS FOR MC  
 VACUUM CHUCKS  
 PROMELTA SYSTEM  
 SINE BAR CHUCKS  
 MAGNETIC BLOCKS  
 WORKING TOOLS  
 MEASURING TOOL HOLDERS  
 MAGNETIC HOLDERS  
 MAGNETIC TOOLS